

PROP MOUNT PARTS

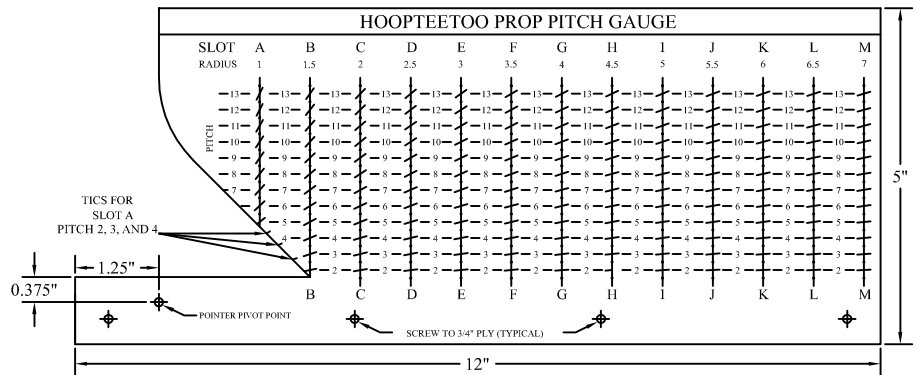
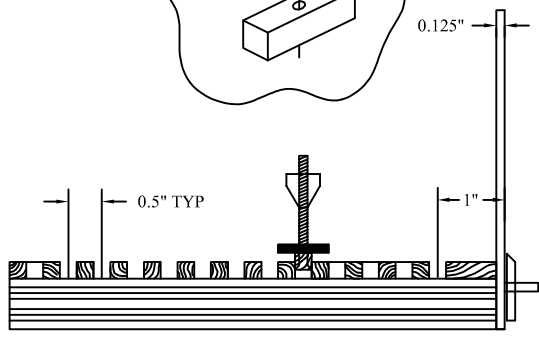
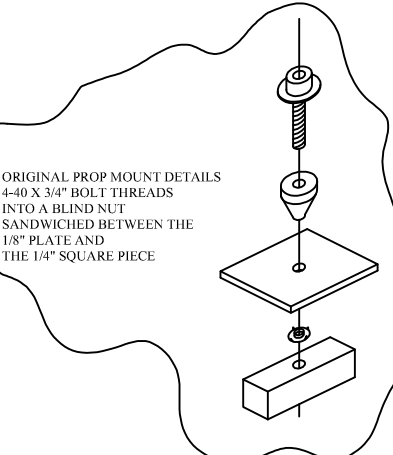
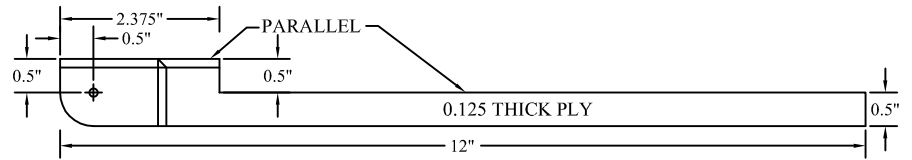
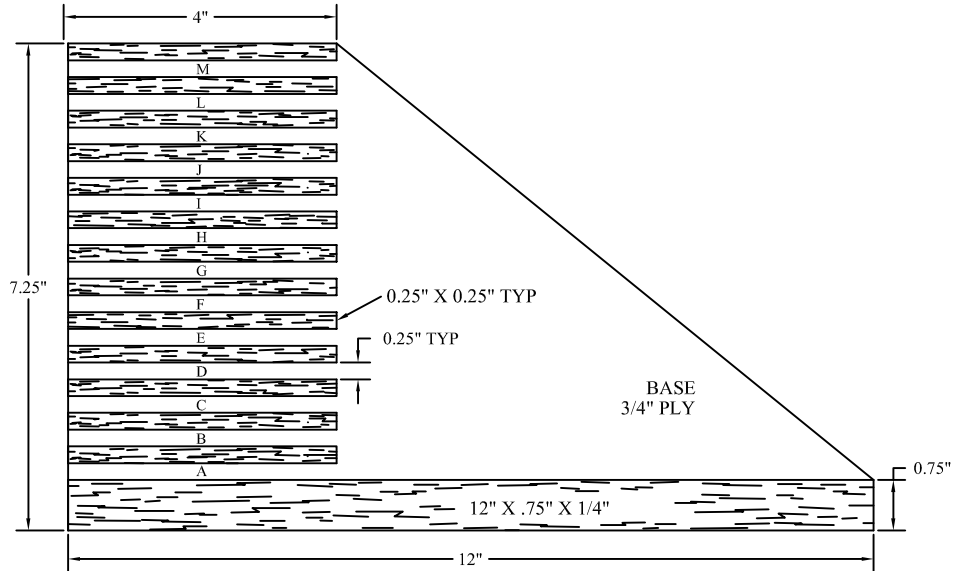
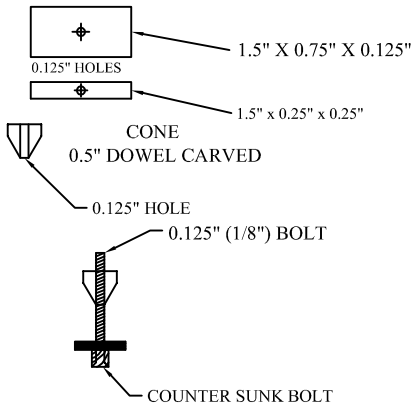

DIRECTIONS

LOCK PROP TO PROP MOUNT WITH CONE ON TOP OF PROP  
 PLACE PROP MOUNT IN A SLOT SUCH THAT PROP EXTENDS FRONT TO BACK  
 SLIDE PROP LEFT AND RIGHT TILL THE POINTER EDGE TOUCHES THE BLADE BOTTOM  
 POINTER EDGE SHOULD TOUCH THE BLADE BOTTOM AND BE PARALLEL TO IT  
 FIND THE VERTICAL LINE THAT CORRESPONDS TO THE SLOT BEING USED  
 READ THE PITCH FROM INTERSECTION POINT OF POINTER TOP EDGE AND VERTICAL LINE

SCALE INCHES



HOOPTREETOO PROP PITCH GAUGE

UPDATED HOOPTREE PITCH GAUGE  
 INCREASED RADIUS TO 7"

Special Thanks To Mr. John F. Kilsdonk  
 Originator Of The Hooptee Pitch Gauge

Drawn By: John Byrne  
 Calculations by John Byrne  
 johnbyrne@bellsouth.net

Last Rev  
 1/9/09